

ITEM QTY	P/N	DESCRIPTION
1	005110M	BASE, ELECT, SENTINEL
2	000980	BLADE-HI INT. W/STROBE LEDS
3	005045	TAB, ALUM BLADE PROTECTOR - RED
4	007000	WINDGUARD, PAINTED

REV.	DATE	BY	NOTES
A	7/12/07	GCM	ADD (1) 005045 & WIRING INFORMATION

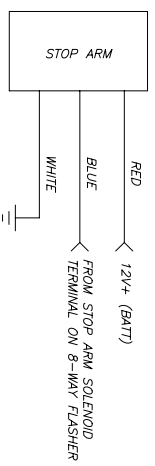
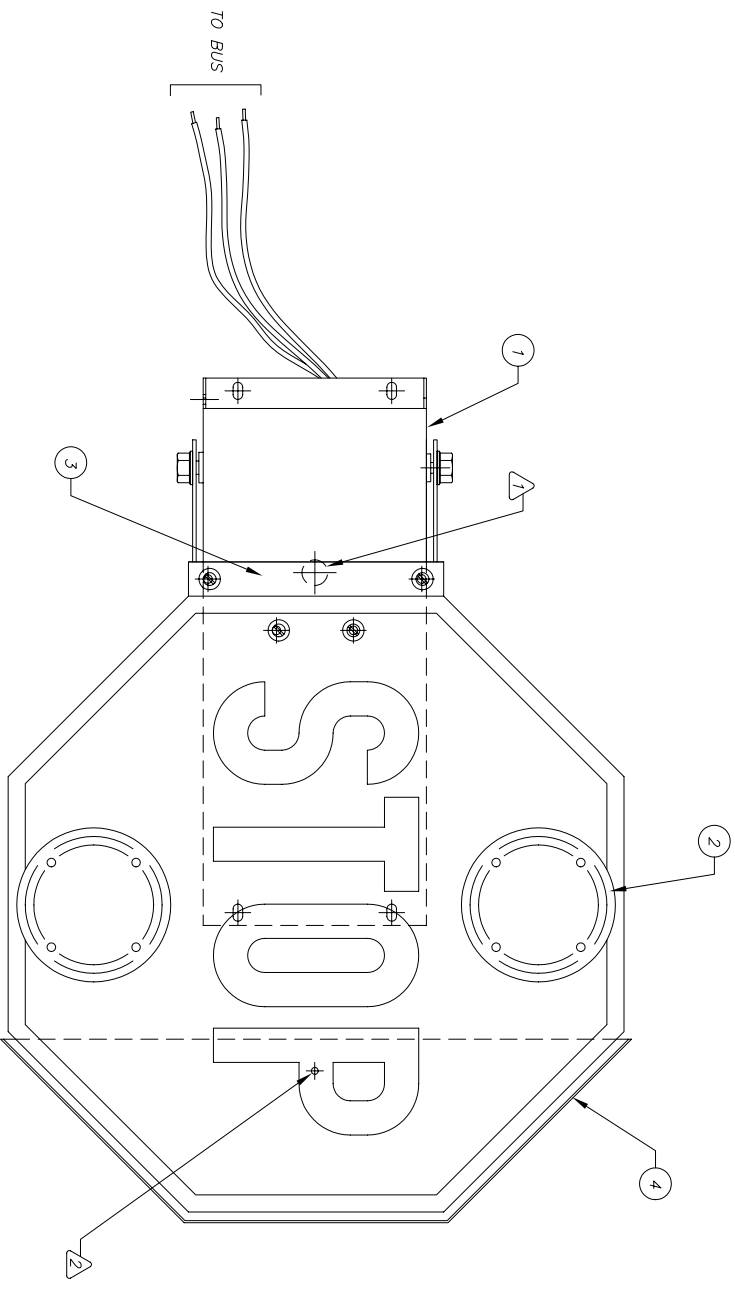

NOTES

- 1 HARNES LOCATION. STANDARD WIRING INCLUDES 16 GA LEADS 3 FEET IN LENGTH.
- 2 INSTALL WINDGUARD FASTENER AFTER TIGHTENING BASE FASTENERS.
- 3 MEETS FINSS131 (INCLUDES SAE STANDARD J1133)
- 4 INSTALLED THICKNESS: 3.5"
- 5 MAXIMUM PROTRUSION AT FULL OPEN POSITION: 23.5" (MEASURED FROM BACK MOUNTING SURFACE OF UNIT).
- 6 WIRE IDENTIFICATION: RED - STOP ARM POWER
BLUE - STOP ARM ACTUATION
YELLOW - HEATER POWER
WHITE - GROUND

WIRING DIAGRAM

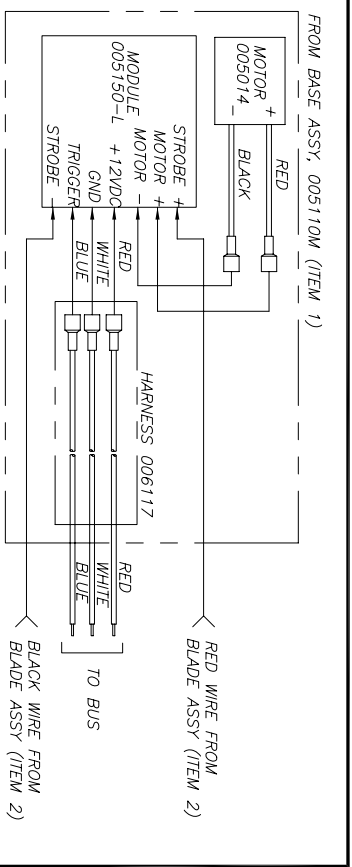

10200 PINEVILLE ROAD
P.O. BOX 790
PINEVILLE, NC 28134

DRAWN BY: DATE: 1/15/07

MATERIAL: SEE BOM

FINISH:

SCALE: 1 OF 1 SHEET B

TOLERANCES (EXCEPT AS NOTED) DECIMAL: ± .010

ANGULAR: ± 1°

THE INFORMATION CONTAINED HEREIN IS THE PROPRIETARY DATA OF SPECIALTY MANUFACTURING INC., AND IS NOT FOR DISSEMINATION OR DISCLOSURE IN WHOLE OR IN PART, FOR ANY PURPOSE OTHER THAN THAT FOR WHICH IT IS SUBMITTED, EXCEPT AS EXPLICITLY AUTHORIZED IN WRITING BY SPECIALTY MANUFACTURING INC.

STOP ARM - ELEC., HI-INT, STRB LEDS

DIRECTORY	DRAWING/PART NO.	REV.
...MAIN	005980M	A
FILE NAME		
005980MA		