

ITEM QTY	P/N	DESCRIPTION
1	005110M	ASSY. SENTINEL ELECTRIC BASE S/A
2	000900-1	BLADE-HI-INT. W/ LIGHTS
3	005045	TAB. ALUM. BLADE PROTECTOR - RED
4	007200	WINDGUARD, PAINTED

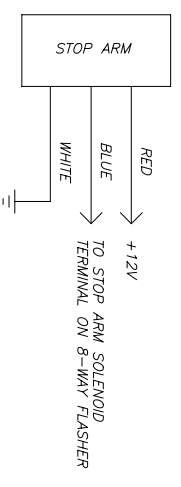

**NOTES**

1. HARNESS LOCATION. STANDARD WIRING INCLUDES 16 GA LEADS 3 FEET IN LENGTH.
2. INSTALL WINDGUARD FASTENER AFTER TIGHTENING BASE FASTENERS.
3. MEETS FMVSS131 (INCLUDES SAE STANDARD J1133)
4. INSTALLED THICKNESS: 3.5" (FROM SIDE OF BUS)
5. MAXIMUM PROTRUSION AT FULL OPEN POSITION: 23.5" (MEASURED FROM BACK MOUNTING SURFACE OF UNIT).
6. WIRE IDENTIFICATION: RED - STOP ARM POWER  
BLUE - STOP ARM ACTIVATION  
WHITE - GROUND

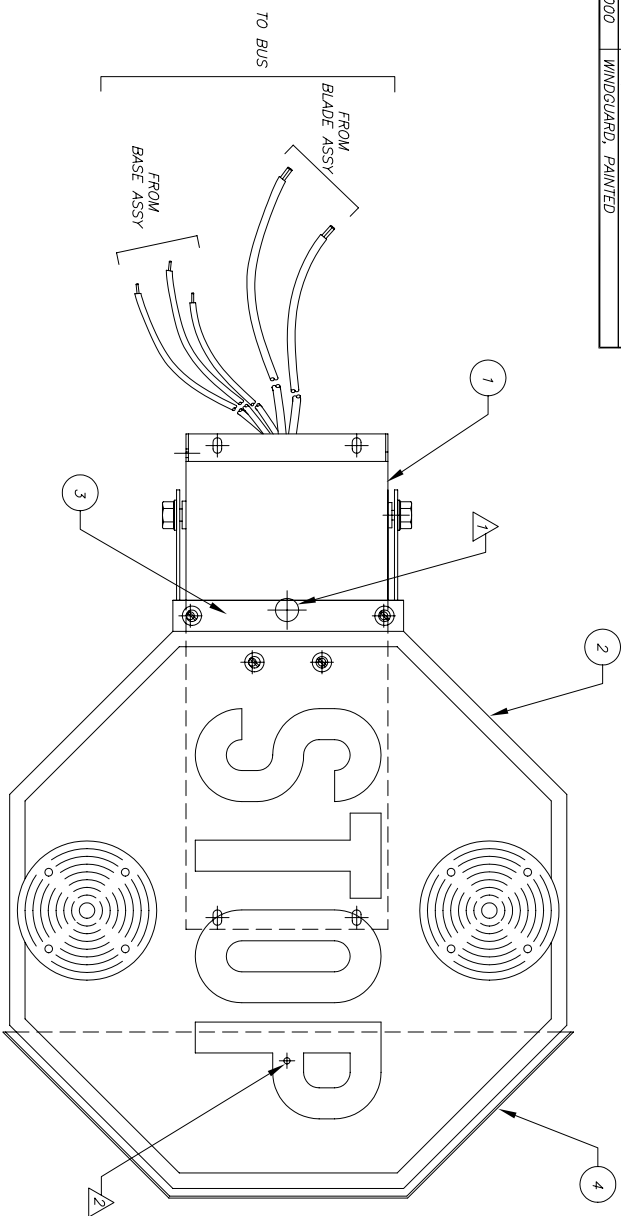
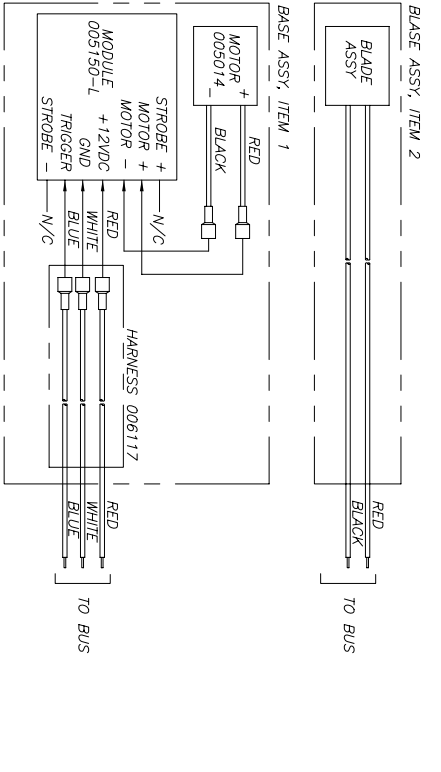

WIRING DIAGRAM

REV.	DATE	BY	NOTES

<b>SPECIALTY MANUFACTURING INC.</b>		DRWGN: BT	DATE: 7/2/07
10200 PINEVILLE ROAD P.O. BOX 790 PINEVILLE, NC 28134		MATERIAL: SEE BOM	
FINISH: SEE BOM		SCALE: 1 SHEET 1 OF 1	SIZE: D
TOLERANCES (EXCEPT AS NOTED): DECIMAL: .005 ± .010 ANGULAR: ± 1°		THE INFORMATION CONTAINED HEREIN IS THE PROPERTY OF SPECIALTY MANUFACTURING INC. FOR ANY PURPOSE OTHER THAN THAT FOR WHICH IT IS SUBMITTED, PROJECT AS DEFINED IN WRITING BY SPECIALTY MANUFACTURING INC.	
DESCRIPTION: STOP ARM, SENTINEL ELECTRIC HI-INT W/ LIGHTS		DIRECTOR: ...MAIN	REV: -
DRAWING/PART NO. 005900M			